

ORACAL®

Glass Design



ORAFOL®

Engineered to Perform Better™

ORACAL Glass Design

La gamme ORACAL GLASS DESIGN est une gamme de films polyester décoratifs haut de gamme pour le vitrage. Cette gamme offre un choix de seize films différents aux motifs variés.

Classée feu M1, la gamme ORACAL GLASS DESIGN est garantie sans PVC et sans solvants, ce qui est donc idéal pour la décoration de lieux recevant du public. Autre avantage, ces produits permettent de garantir la confidentialité des locaux sans obscurcir la pièce où ils sont appliqués.

Enfin, ces films sont faciles à transformer : déjà imprimés, ces produits sont prêts à être appliqués et évitent le processus fastidieux d'échenillage.

A propos d'ORAFOL





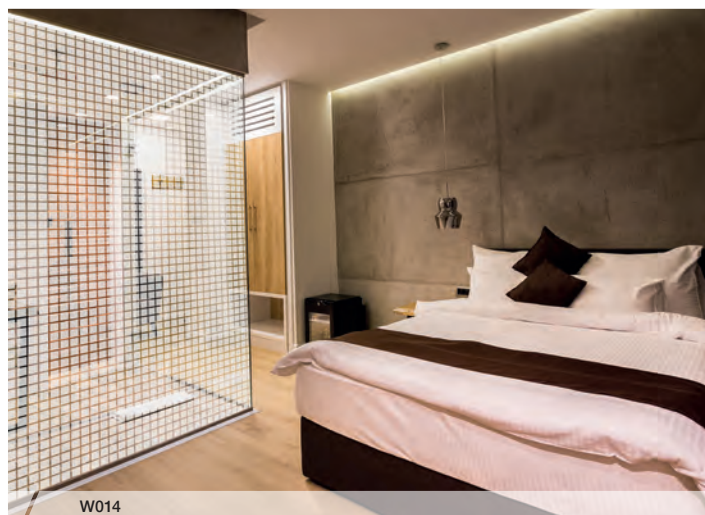











ORAFOL Europe GmbH est le plus gros enducteur d'Europe avec vingt-neuf lignes d'enduction destinées aux marchés graphiques, aux films rétro réfléchissants et aux rubans techniques. Situé à Oranienbourg, aux portes de Berlin et au cœur de l'Europe, le siège mondial d'ORAFOL s'étend sur plus de 250 000 m² et emploie 1 000 personnes en production, R&D, logistique et vente.

ORAFOL Europe GmbH est certifiée conformément aux normes EN ISO 9001 et EN ISO 14001, et toute la production s'effectue sur les équipements les plus avancés et les plus fiables existant à l'heure actuelle dans l'industrie, ce qui permet d'affirmer plus que jamais que les produits ORAFOL sont « *engineered to perform better* ».



Index

ORACAL® Glass Design

Nom	Page	Nom	Page
 W001	4	 UV11	12
 W014	5	 WM20	13
 UV05	6	 DX01	14
 G002	7	 DX02	15
 W002	8	 DX03	16
 W018	9	 DX04	17
 W004	10	 DX05	18
 UV10	11	 DX06	19



DX04

W001



FRONTAL	Film polyester
MOTIF	Bandes blanches 4 mm
ÉPAISSEUR	38µ
COLLE	Acrylique copolymère
DURABILITÉ	5 ans
LAIZE	1525 mm
ROULEAU	30 m

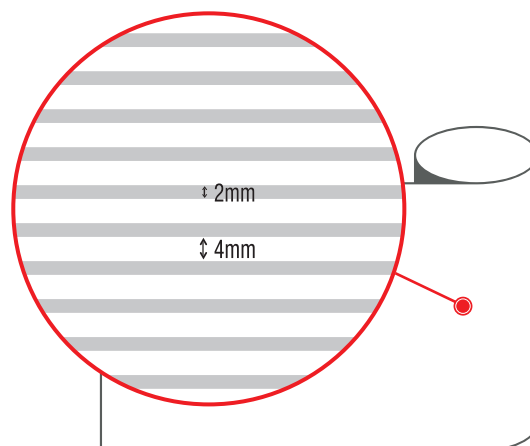

Prêt à
poser !

W014



FRONTAL	Film polyester
MOTIF	Carrés blancs 20mm
ÉPAISSEUR	38 μ
COLLE	Acrylique copolymère
DURABILITÉ	5 ans
LAIZE	1525 mm
ROULEAU	30 m

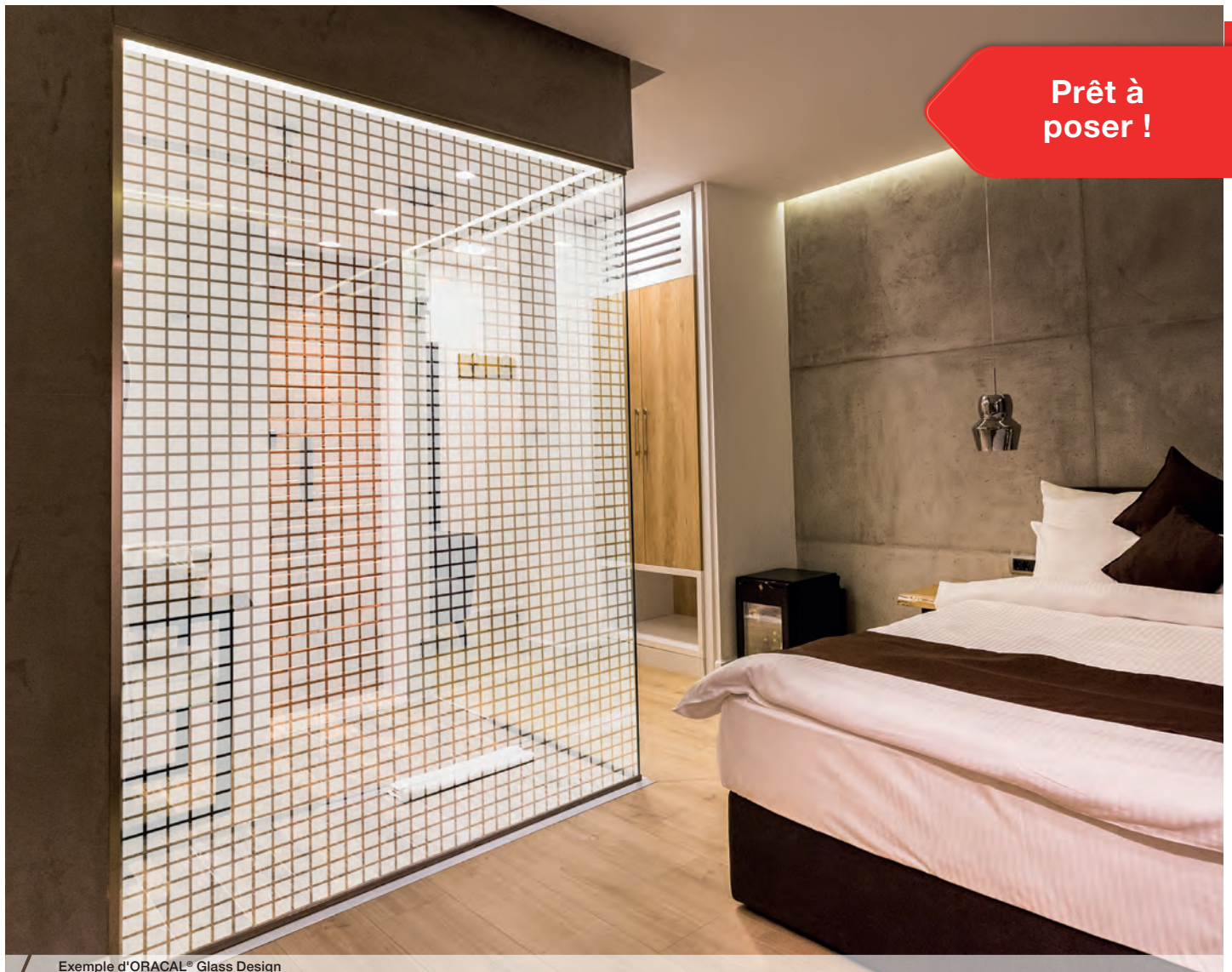
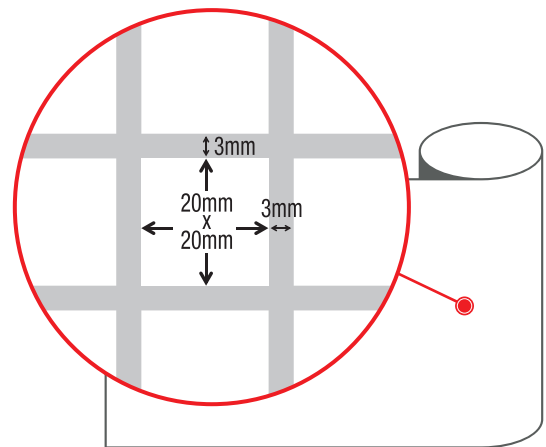

Prêt à
poser !

UV05



FRONTAL	Film polyester
MOTIF	Bandes effet dépoli 35 mm
ÉPAISSEUR	38 μ
COLLE	Acrylique copolymère
DURABILITÉ	5 ans
LAIZE	1525 mm
ROULEAU	30 m

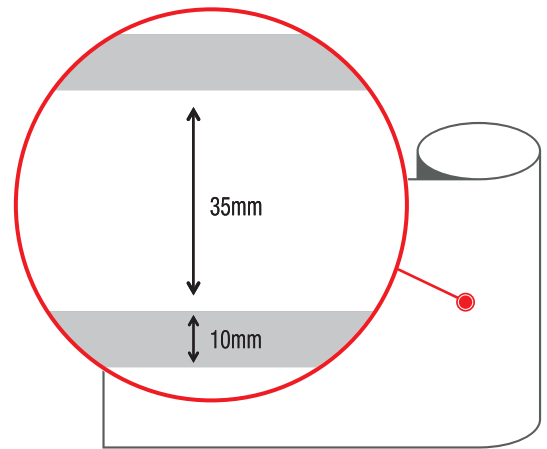

**Prêt à
poser !**



G002



FRONTAL	Film polyester
MOTIF	Bandes grises 10mm
ÉPAISSEUR	38µ
COLLE	Acrylique copolymère
DURABILITÉ	5 ans
LAIZE	1525mm
ROULEAU	30m

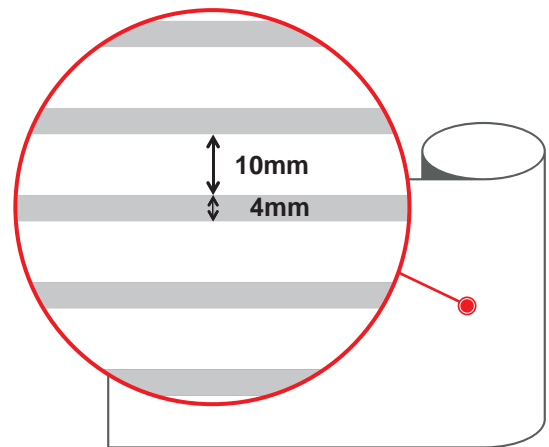

Exemple d'ORACAL® Glass Design

W002



FRONTAL	Film polyester
MOTIF	Bandes blanches 10mm
ÉPAISSEUR	38µ
COLLE	Acrylique copolymère
DURABILITÉ	5 ans
LAIZE	1525 mm
ROULEAU	30m

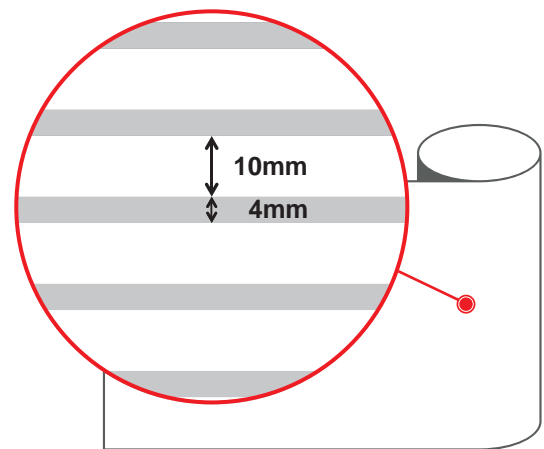

Prêt à
poser !



Exemple d'ORACAL® Glass Design

W018



FRONTAL	Film polyester
MOTIF	Cocon blanc
ÉPAISSEUR	38μ
COLLE	Acrylique copolymère
DURABILITÉ	5 ans
LAIZE	1525mm
ROULEAU	30m

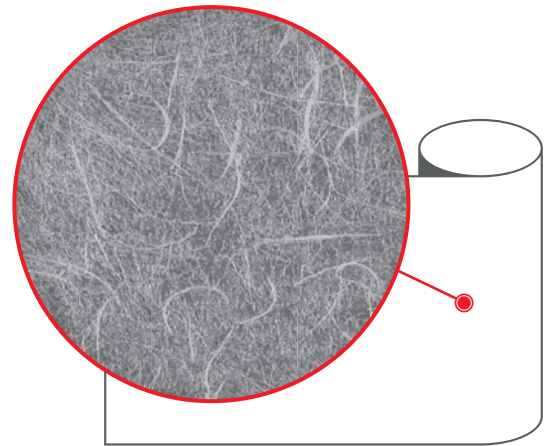

Prêt à poser !

Exemple d'ORACAL® Glass Design

W004



FRONTAL	Film polyester
MOTIF	Bandes blanches 30mm
ÉPAISSEUR	38μ
COLLE	Acrylique copolymère
DURABILITÉ	5 ans
LAIZE	1525mm
ROULEAU	30m

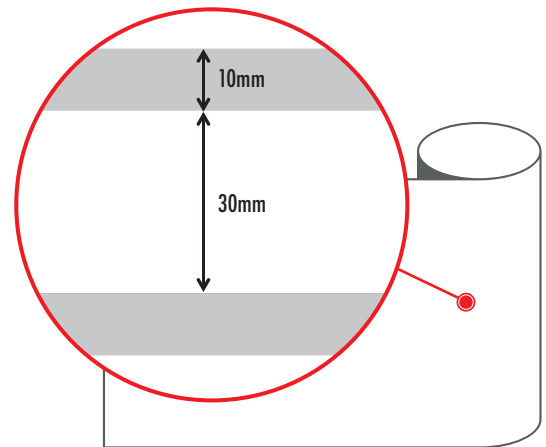

UV10



FRONTAL	Film polyester
MOTIF	Bandes alternées effet dépoli 5 mm et 35 mm
ÉPAISSEUR	38 μ
COLLE	Acrylique copolymère
DURABILITÉ	5 ans
LAIZE	1525 mm
ROULEAU	30 m

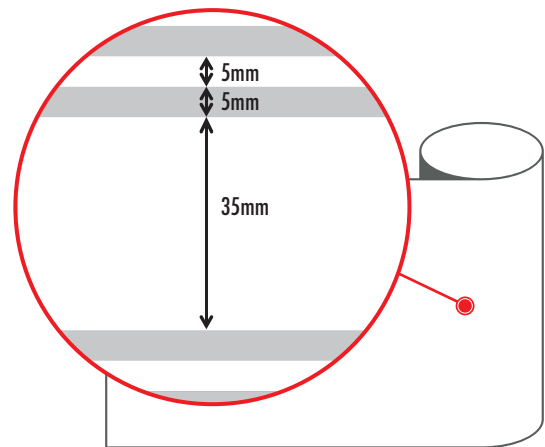

UV11



FRONTAL	Film polyester
MOTIF	Carrés effet dépoli 44 mm
ÉPAISSEUR	38µ
COLLE	Acrylique copolymère
DURABILITÉ	5 ans
LAIZE	1525 mm
ROULEAU	30 m

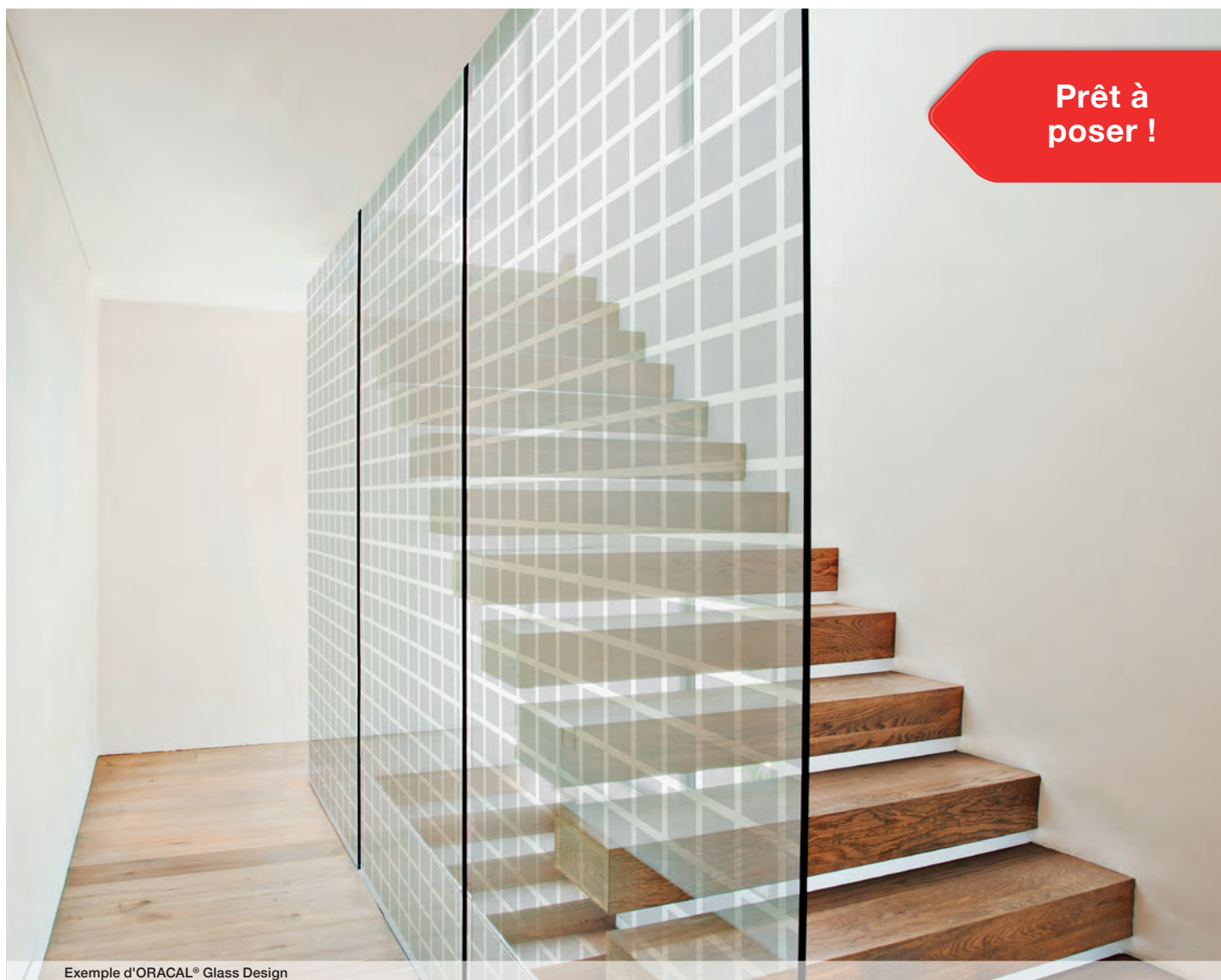
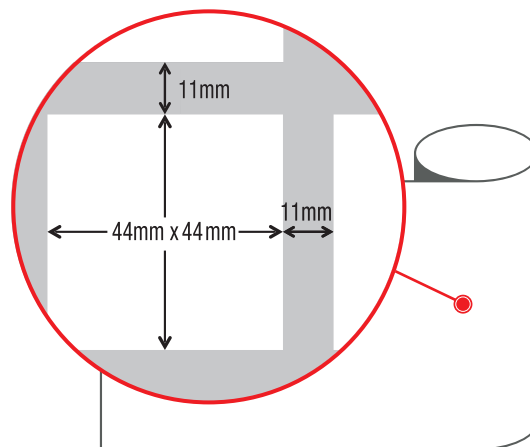

**Prêt à
poser !**

WM20



FRONTAL	Film polyester
MOTIF	Blanc mat
ÉPAISSEUR	38 μ
COLLE	Acrylique copolymère
DURABILITÉ	5 ans
LAIZE	1525 mm
ROULEAU	30 m

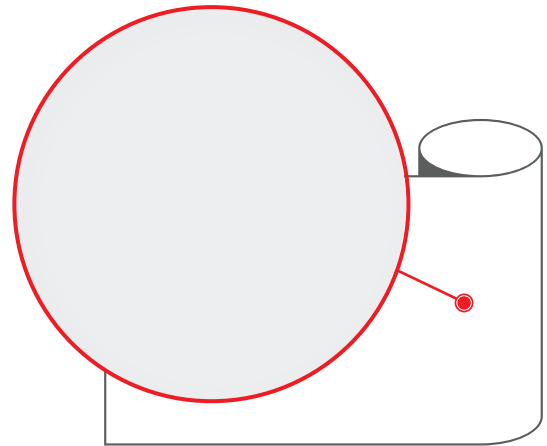

DX01



FRONTAL	Film polyester
MOTIF	Lignes verticales blanches
ÉPAISSEUR	50µ
COLLE	Acrylique copolymère
DURABILITÉ	5 ans
LAIZE	1270mm
ROULEAU	30m

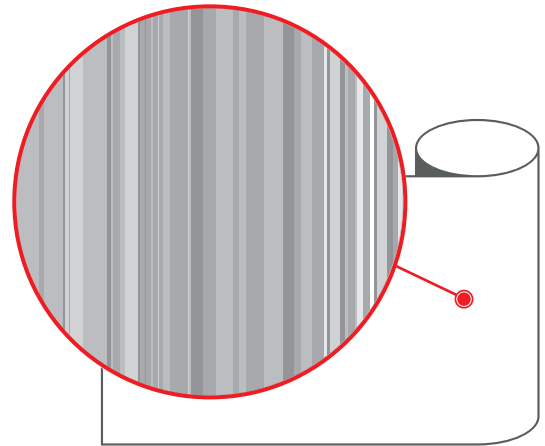

**Prêt à
poser !**

DX02



FRONTAL	Film polyester
MOTIF	Grilles blanches
ÉPAISSEUR	50µ
COLLE	Acrylique copolymère
DURABILITÉ	5 ans
LAIZE	1270mm
ROULEAU	30m

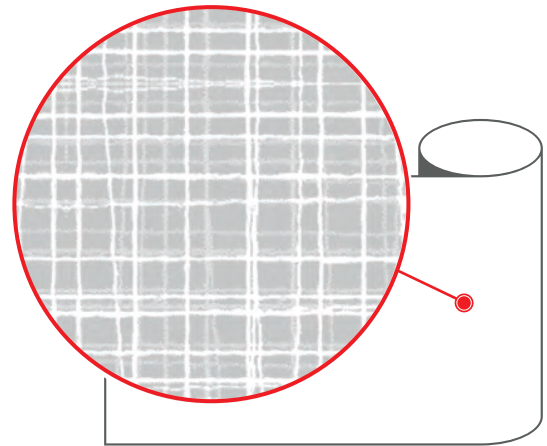

Exemple d'ORACAL® Glass Design

DX03



FRONTAL	Film polyester
MOTIF	Points blancs 3mm
ÉPAISSEUR	50μ
COLLE	Acrylique copolymère
DURABILITÉ	5 ans
LAIZE	1270mm
ROULEAU	30m

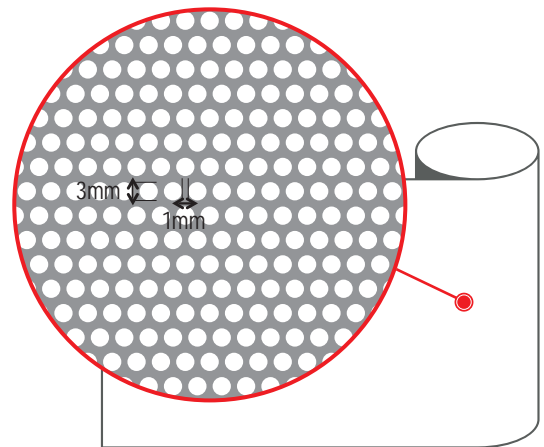

Prêt à
poser !

DX04



FRONTAL	Film polyester
MOTIF	Points blancs dégradés
ÉPAISSEUR	50µ
COLLE	Acrylique copolymère
DURABILITÉ	5 ans
LAIZE	1270mm
ROULEAU	30m

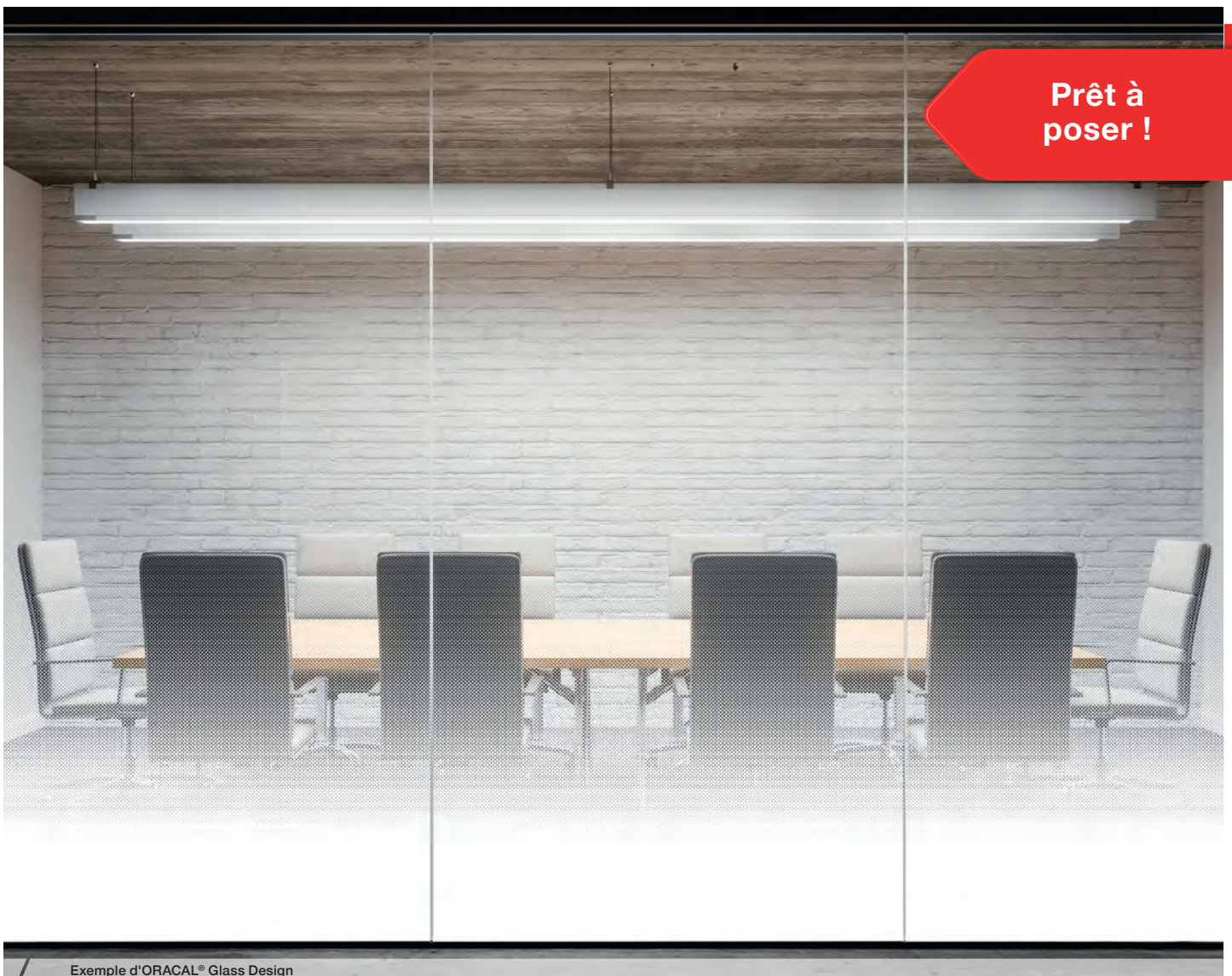
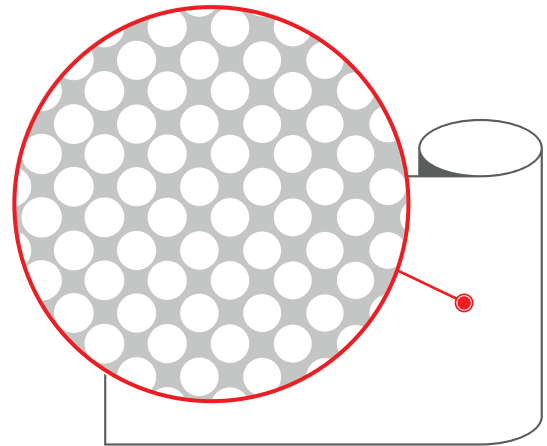

DX05



FRONTAL	Film polyester
MOTIF	Lignes verticales avec points blancs dégradés
ÉPAISSEUR	50µ
COLLE	Acrylique copolymère
DURABILITÉ	5 ans
LAIZE	1270mm
ROULEAU	30m

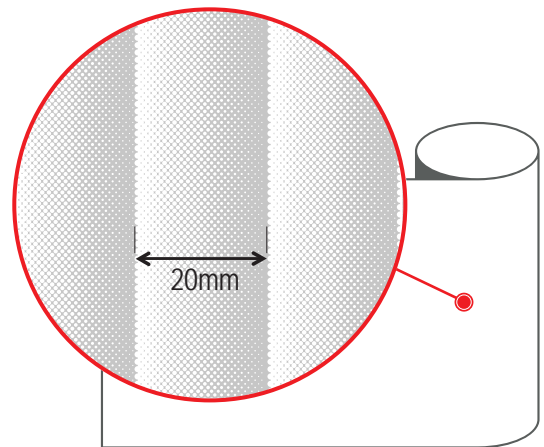

Exemple d'ORACAL® Glass Design

DX06



FRONTAL	Film polyester
MOTIF	Diamants gris et blancs
ÉPAISSEUR	50 μ
COLLE	Acrylique copolymère
DURABILITÉ	5 ans
LAIZE	1270 mm
ROULEAU	30 m

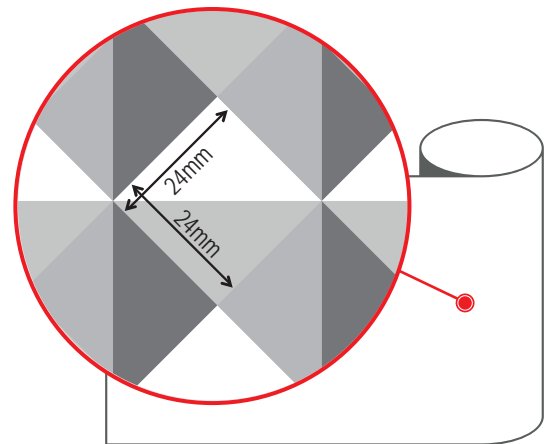

Exemple d'ORACAL® Glass Design



ORACAL®

**Glass
Design**

Distribué par :

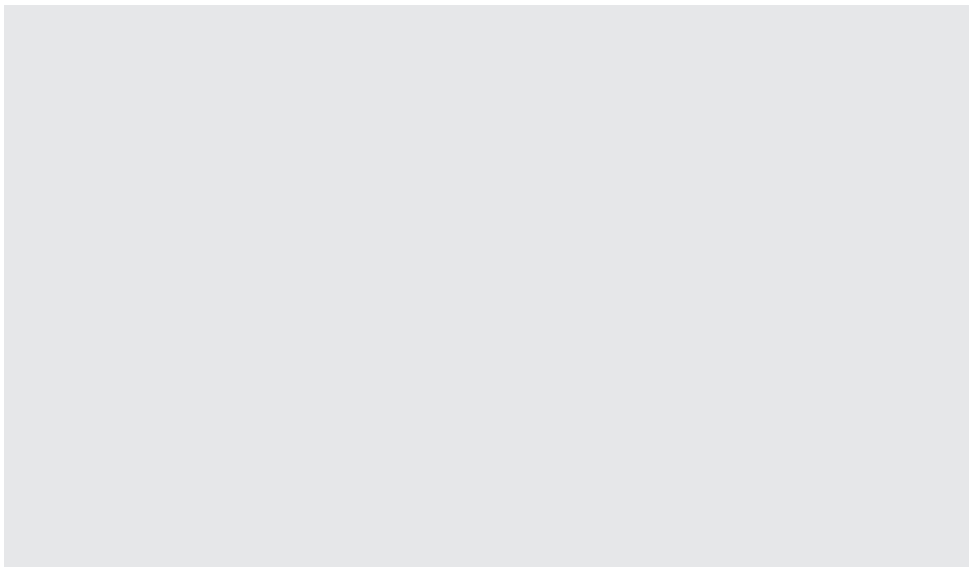

Engineered to Perform Better™